

DATE  
January 20, 2009  
CAT. #:

OUTLINE DIMENSIONS  
3-PHASE INDUCTION MOTOR

MOTOR TYPE:  
AEHH8B-CF  
FRAME NO. 364TC

Pole	HP	kW	Hz	VOLT	Syn. Speed r/min(rpm)
4/6/8	.	.	.	.	.

Ins	Rating	Dimension in	Approx Weight	Bearings
F	CONT.	inches	920 LBS	DE: 6313ZC3 NDE: 6213ZC3

Totally Enclosed Fan Cooled Type. Squirrel-cage Rotor.

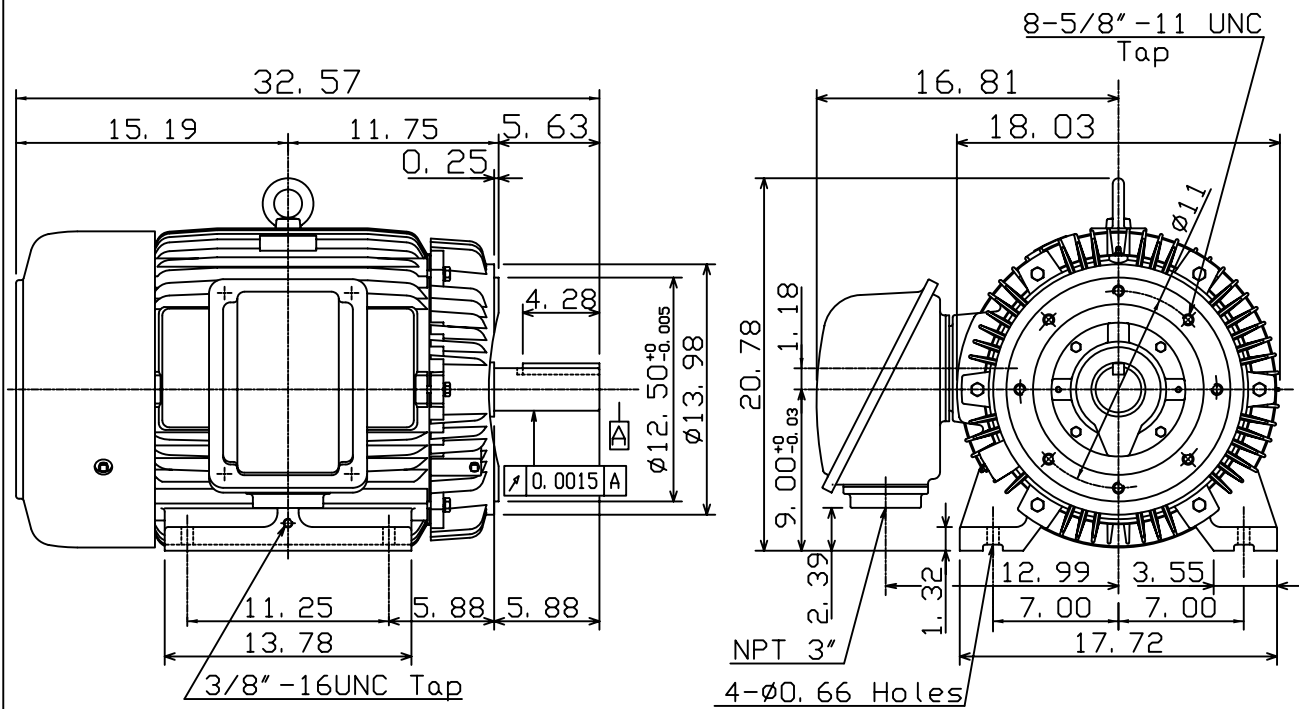

- Note:
1. Motor Vibration: 15 $\mu$ .
  2. Inpro/Seal in Both End Brackets

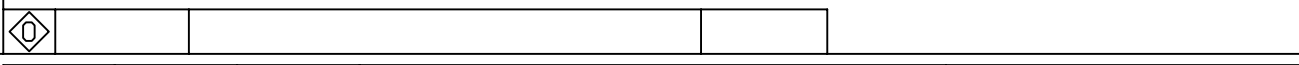
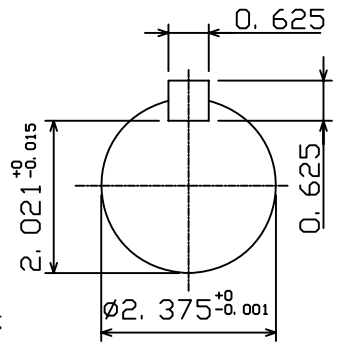

DWN.	K. L. KUO	01-19-05
CHKD.	C. H. KAO	02-01-05
APPD.	M. C. TSAI	02-01-05



DWG NO.  
31049M631400